

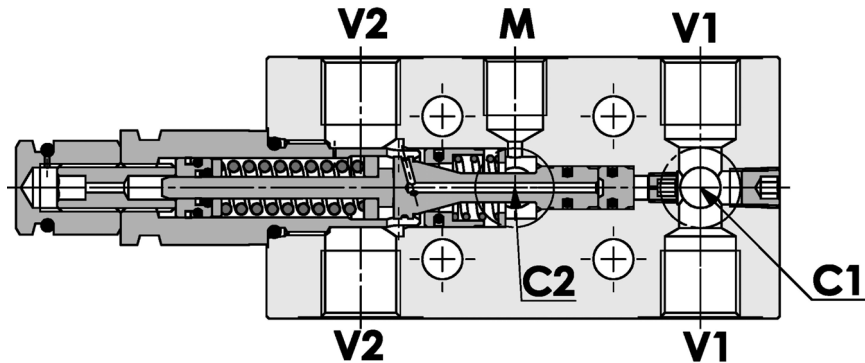

Valvola overcenter singola parzialmente bilanciata, montaggio con C1-C2 flangiate, attacco manometro
Partially balanced single overcenter valve, gasket mounted: C1-C2 flanged, pressure gauge port

Rev.03-2010/08

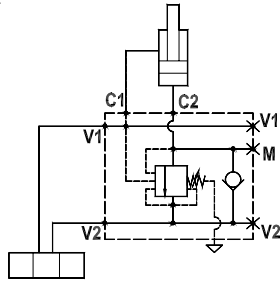

SPECIFICHE TECNICHE

Materiali: corpo in acciaio zincato. I componenti interni sono in acciaio trattato termicamente.

Portata max.: 50 l/min

Taratura max.: 350 bar

Rapporto di pilotaggio: 1 : 4.25 (a richiesta 1 : 8, 1 : 11)

Regolazione pressione: mediante vite

Campo di regolazione pressione: vedere pag.02

TECHNICAL SPECIFICATIONS

Materials: body is steel made zinc plated. Internal parts are in hardened steel.

Rated flow: up to 50 l/min

Max. setting: 350 bar

Pilot ratio: 1 : 4.25 (1 : 8 and 1 : 11 on request)

Adjustment means: leakproof screw adjustment

Adjustable pressure range: see page 02

DIAGRAMMA PERDITE DI CARICO - PRESSURE DROP CURVES

Viscosità olio 24 mm²/sec. (3,5 °E)
 Temperatura 50 °C

Oil viscosity 24 mm²/sec. (3,5 °E)
 Temperature 50 °C

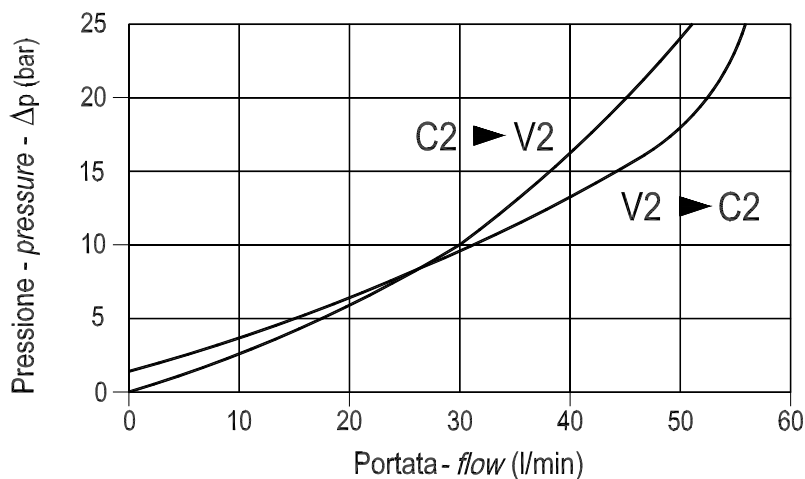

Valvola overcenter singola parzialmente bilanciata, montaggio con C1-C2 flangiate, attacco manometro
Partially balanced single overcenter valve, gasket mounted: C1-C2 flanged, pressure gauge port

Rev.03-2010/08

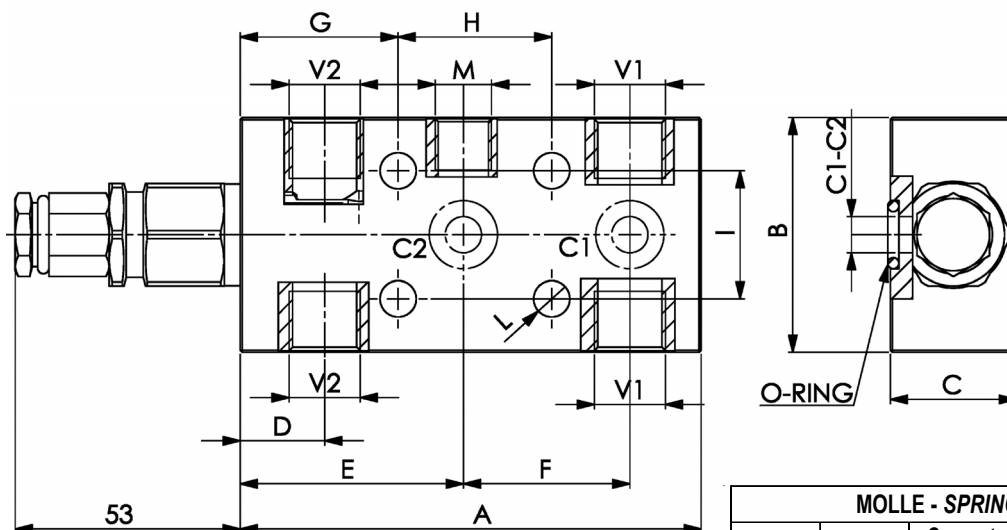

MOLLE - SPRINGS				*
Codice Code	Rapp. pil. Pilot ratio	Campo taratura min.-max. bar Adjustable pressure range bar	Increment. press. bar/giro vite Pressure increase bar/turn	Taratura standard bar Standard setting bar
20	1 : 4.25	60 - 210	70	170
	1 : 8	60 - 220	50	
	1 : 11	60 - 250	90	
35	1 : 4.25	80 - 350	120	280
	1 : 8	100 - 350	85	
	1 : 11	80 - 350	150	

TIPO TYPE	V1-V2	C1-C2	A	B	C	D	E	F	G	H	I	L	O-RING	PESO WEIGHT
	BSPP	mm	mm	mm	mm	mm	mm	mm	mm	mm	mm	mm	mm	Kg
FPOB-50-S-1/4"-2F-P-M	1/4"	9	108	55	30	19.5	52	39	37	36	30	8.5	10.77x2.62	1.210
FPOB-50-S-3/8"-2F-P-M	3/8"	9	108	55	30	19.5	52	39	37	36	30	8.5	10.77x2.62	1.210
FPOB-50-S-1/2"-2F-P-M	1/2"	9	108	65	35	19.5	52	39	37	36	30	8.5	10.77x2.62	1.790

ESEMPIO DI ORDINAZIONE - ORDERING CODE EXAMPLE

F P O B 5 0 S 1 / 2 2 F P M 2 0 B *

1/4 - 1/4" BSPP
 * 3/8 - 3/8" BSPP
 1/2 - 1/2" BSPP
 Connessioni - Port sizes

* "20" / "35":
 Campi di taratura pressione - Adjustable pressure

Guarnizioni - Seals:
 V=Viton *
 Omettere se BUNA-N
 Omit if BUNA-N

Rapporto di pilotaggio
 Pilot ratio
 Omettere se standard *
 Omit if standard
 B = 1 : 8, C = 1 : 11